

ENGINEERED TO FIT 4" THROUGH 6" BACKFLOW PREVENTION DEVICE INSTALLATIONS

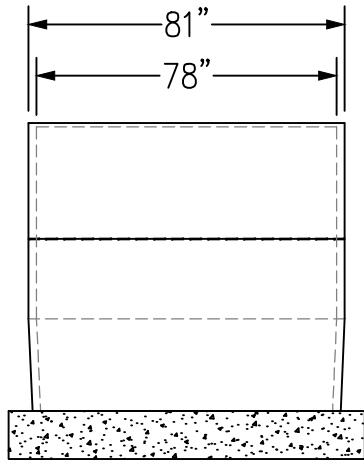

BACK VIEW
NOT TO SCALE

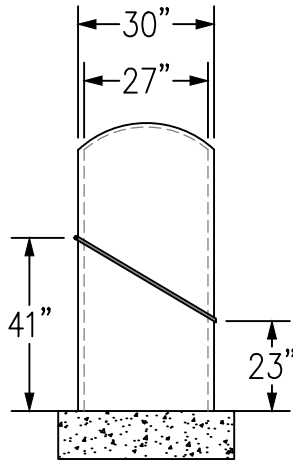

SIDE VIEW
NOT TO SCALE

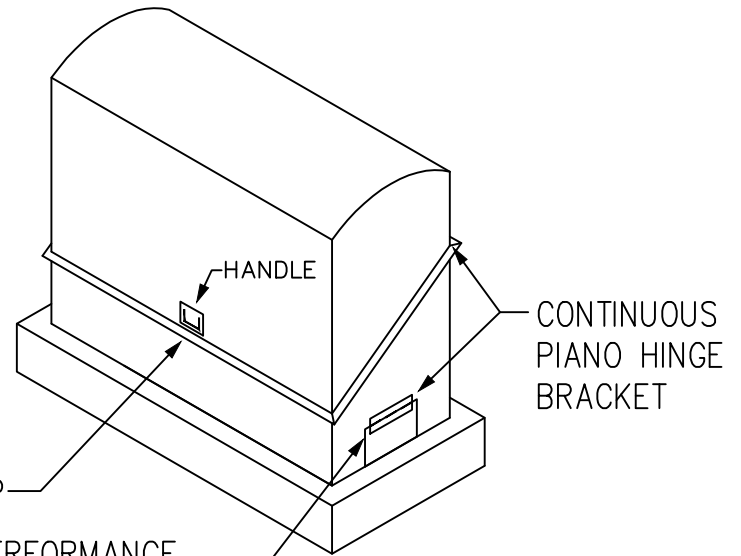

LOCKING HASP

DISCHARGE PERFORMANCE
FLOW RATE (GPM): 720

ISOMETRIC VIEW
NOT TO SCALE

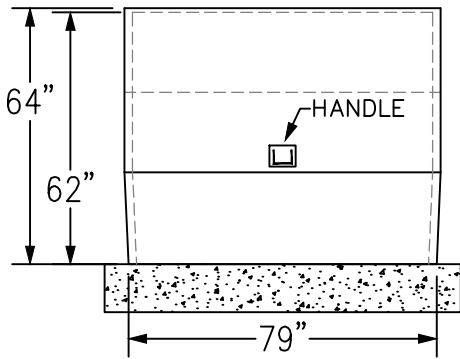

FRONT VIEW
NOT TO SCALE

SLAB OR FOOTER
RECOMMENDED PAD/FOOTER SIZE:
LENGTH: 88" x 38"

SPECIFICATION:

BFProducts Inc. enclosures are manufactured to ASSE-1060 standards and designed to be used to help protect Backflow Prevention Devices from freezing conditions and vandalism. Factory assembled construction will include a gelcoat shell backed with chop-strand polyresin bonded fiberglass, internally insulated using polyurethane spray-foam.
WEIGHT: 195 LBS

Options:

- HU-SS HEATER – Internal Heat Source, Damp Location Listed, 120v, 500w or 1000w, Thermostatically Controlled.

ASSE-1060

BFPRODUCTS
CORPORATE OFFICE
P.O. BOX 242771
CHARLOTTE, NC 28224

PHONE: (704) 599-9407
FAX: (704) 599-0595
EMAIL: bfproducts@qmarketing.biz
WEBSITE: WWW.BFPRODUCTS.BIZ

BFProducts, Inc
Backflow Prevention Device Enclosures
"We've Got You Covered"

FIBERGLASS ENCLOSURE
MODEL # 78-APD
Submittal Sheet

SHEET NO.
08/01/14
78-APD